

MODEL	RATED TORQUE @ STD. AIR GAP		BREAKAWAY TORQUE		MAX RPM
MTD-8	7.5 Nm	66 Lb-in	8.5 Nm	75 Lb-in	10,500

REVISIONS			
REV.	ECN.	DESCRIPTION	DATE

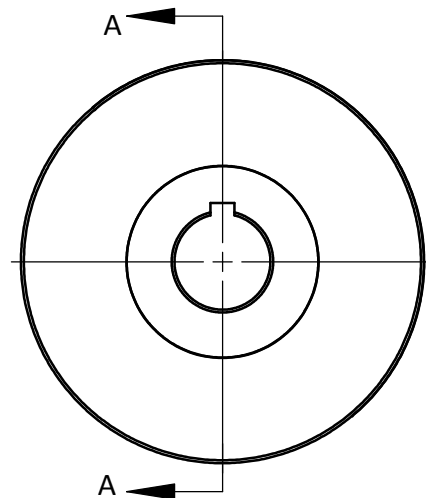

COUPLING HALF:
WEIGHT: 2.55 Lbs (1.16 Kg)

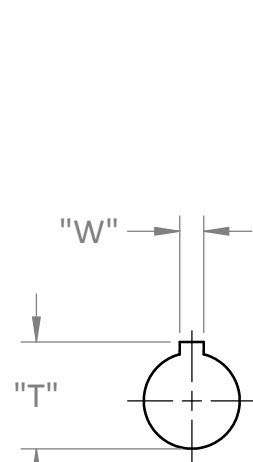
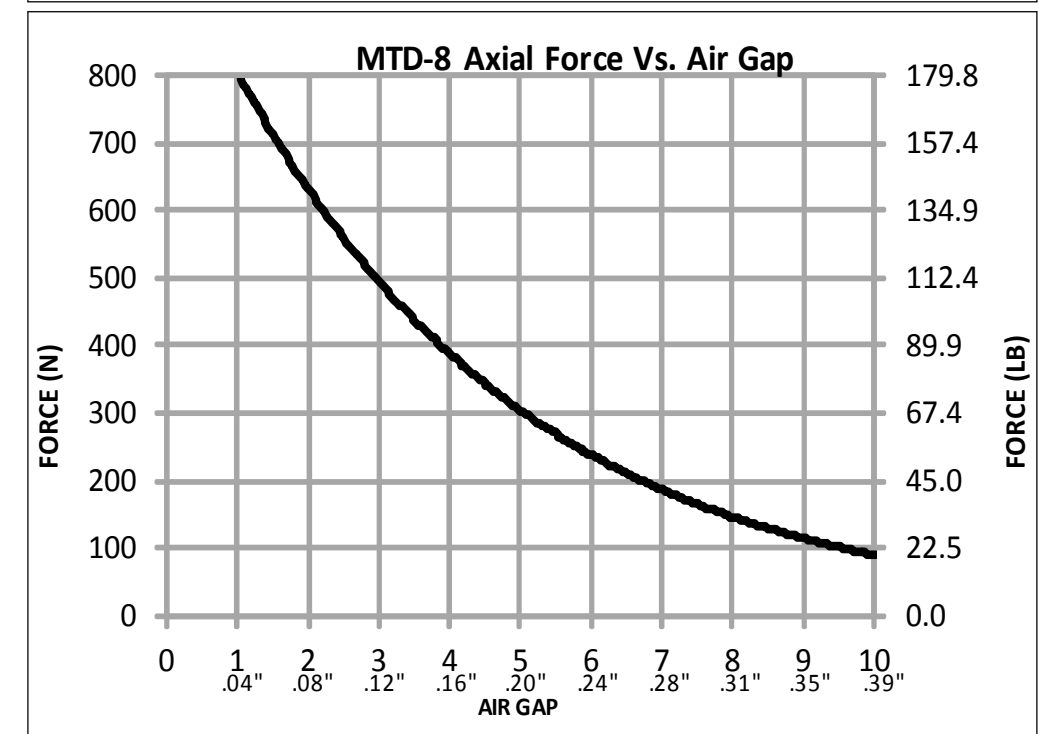
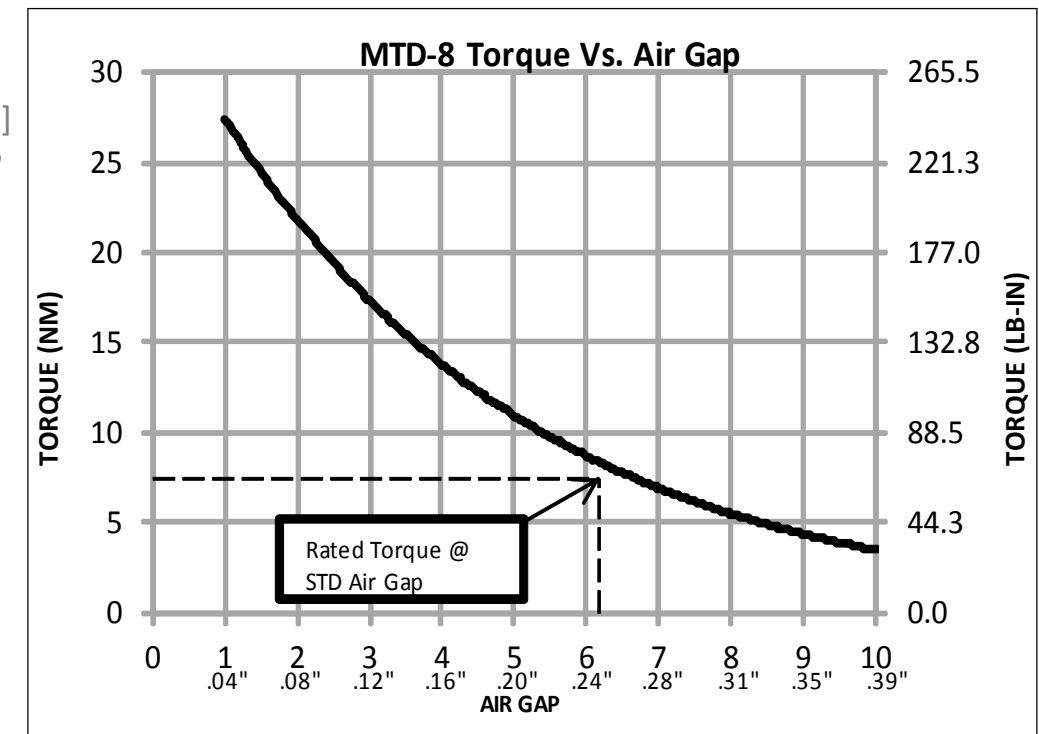
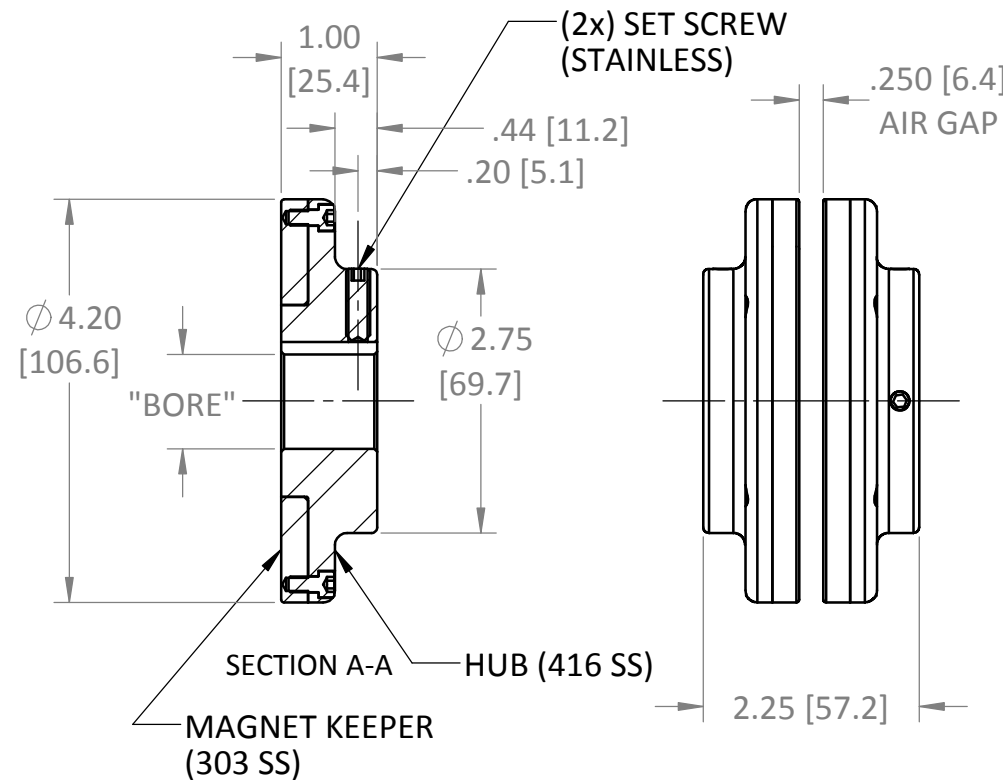

* MODEL	BORE		W		T		SET SCREW (2x)
	mm ^{H8}	in ^{+0.001}	mm ^{+0.05}	in ^{+0.002}	mm ^{+0.25}	in ^{+0.010}	CUP POINT
MTD-8-0000	SOLID		-		-		-
MTD-8-0500	12.70	.500	3.18	.1250	14.22	.560	#10-32 x 3/4
MTD-8-0551	14.00	.551	5.00	.1969	16.30	.642	M5-0.8 x 20 mm
MTD-8-0625	15.88	.625	4.76	.1875	18.00	.709	#10-32 x 3/4
MTD-8-0748	19.00	.748	6.00	.2362	21.80	.858	M5-0.8 x 20 mm
MTD-8-0750	19.05	.750	4.76	.1875	21.26	.837	#10-32 x 3/4
MTD-8-0875	22.23	.875	4.76	.1875	24.49	.964	#10-32 x 3/4
MTD-8-0945	24.00	.945	8.00	.3150	27.30	1.075	M8 -1.25 x 20 mm
MTD-8-0100	25.40	1.000	6.35	.2500	28.30	1.114	1/4-20 x 5/8
MTD-8-0110	28.00	1.102	8.00	.3150	31.30	1.232	M8-1.25 x 20 mm
MTD-8-0112	28.56	1.125	6.35	.2500	31.52	1.241	1/4-20 x 5/8
MTD-8-0125	31.75	1.250	6.35	.2500	34.72	1.367	1/4-20 x 5/8
MTD-8-0137	34.93	1.375	7.94	.3125	38.56	1.518	5/16-18 x 1/2

OTHER SIZES AVAILABLE; SPECIFY BOTH BORE AND KEYWAY

*** ONLY MTD-8-0000 FROM STOCK**

USED ON MTD-8	SCALE 1:2	MATERIAL SEE PRT DWG	MAGNETIC TECHNOLOGIES LTD. 43 TOWN FOREST ROAD OXFORD, MA 01540
UNLESS OTHERWISE SPECIFIED: ALL DIMENSIONS ARE IN INCHES TOLERANCES: DECIMAL: .XX ± .01 .XXX ± .005 ANGULAR: ± 1° GEN. CONCENTRICITY: .001 T.I.R. MACH. FILLETS: .010 R MACH. EDGES: .015 R OR CHMF. UNSPECIFIED RADII: .015 R IN MICROINCHES RMS 32 GEOMETRIC: TO MIL-ST'D. 8 REMOVE ALL BURRS & SHARP EDGES		FINISH SEE PRT DWG	
DRAWN AMD 11/11/14		CHECKED	DESCRIPTION MTD-8 Cut Sheet
SIZE: B			DWG. NO. _____ REV. _____