

MODEL	RATED TORQUE @ STD. AIR GAP		BREAKAWAY TORQUE		MAX RPM
MTD-1	1.0 Nm	9 Lb-in	1.4 Nm	12 Lb-in	19000

REVISIONS			
REV.	ECN.	DESCRIPTION	DATE

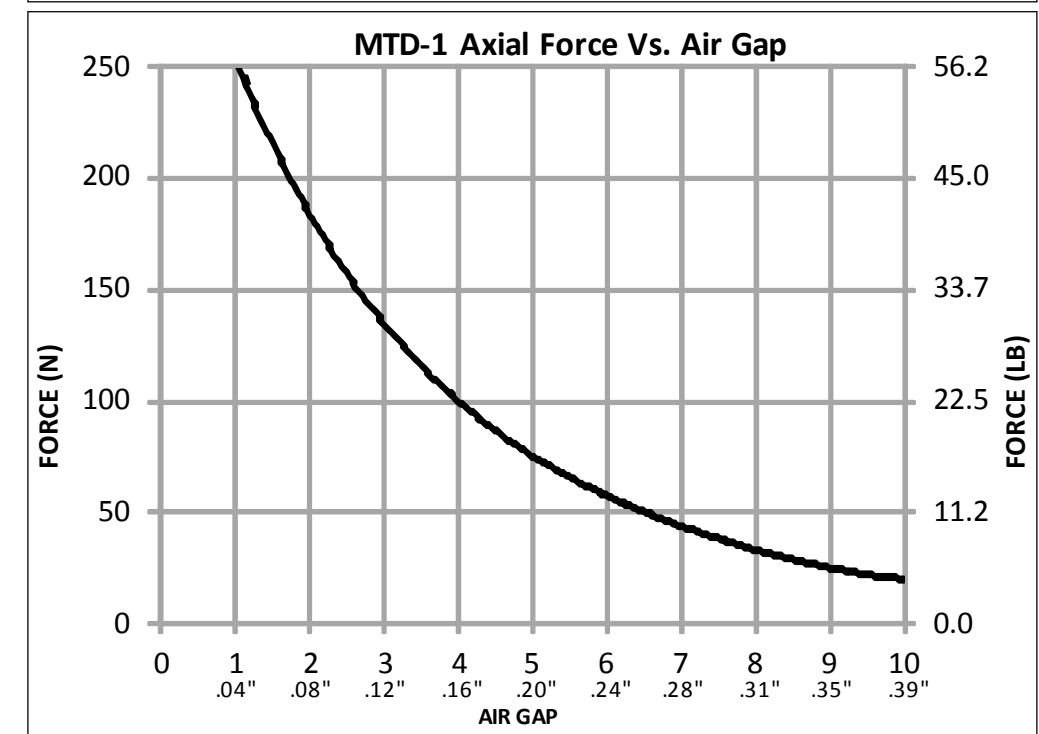
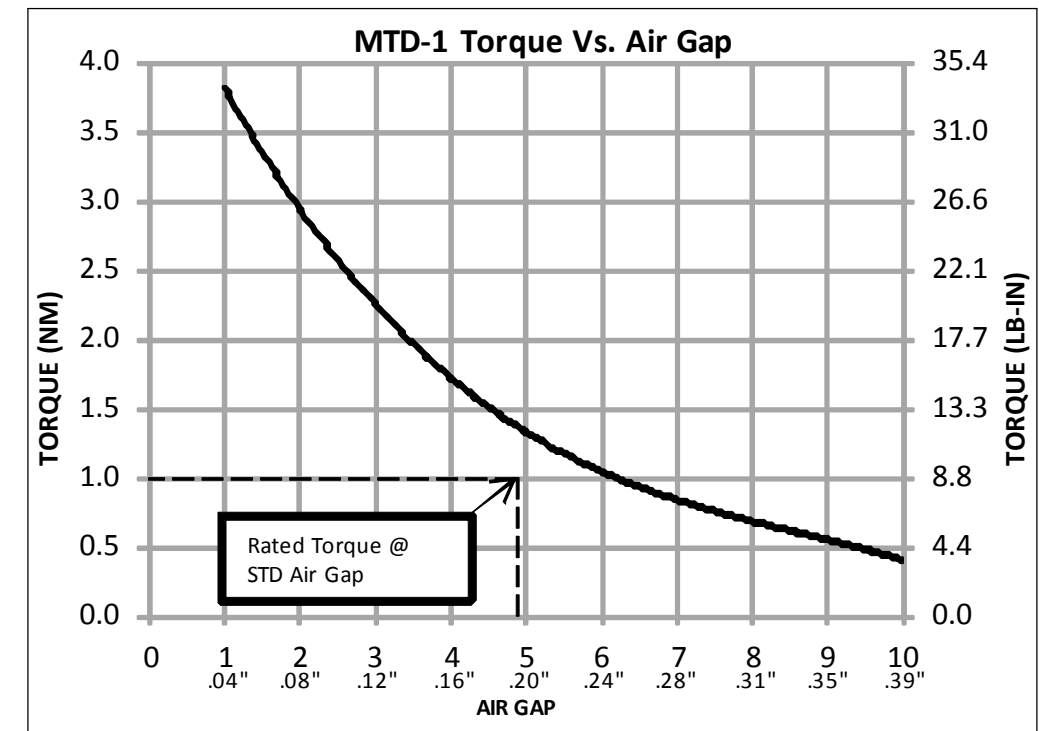
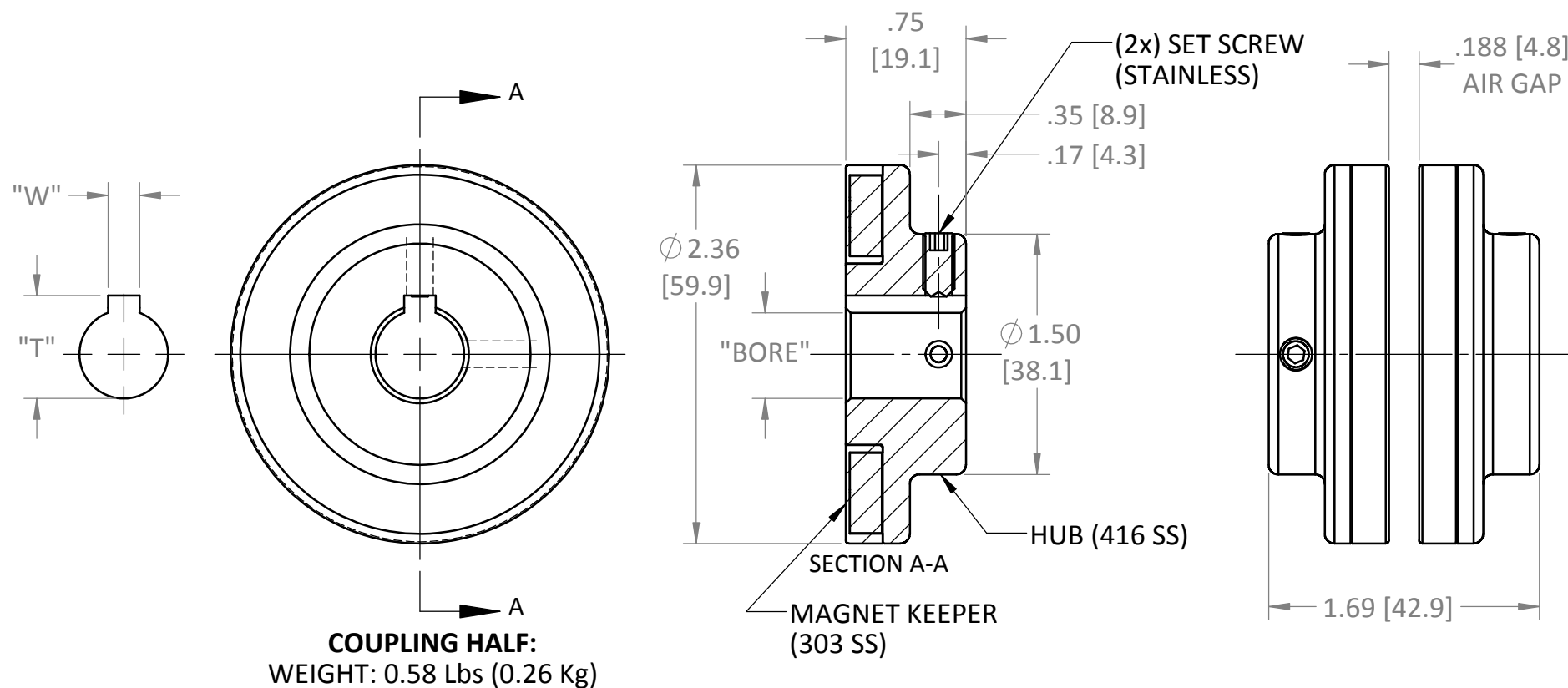

MODEL	BORE		W		T		SET SCREW (2x)
	mm ^{H8}	in ^{+0.001}	mm ^{+0.05}	in ^{+0.002}	mm ^{+0.25}	in ^{+0.010}	CUP POINT
MTD-1-0000	SOLID		-	-	-	-	-
MTD-1-0375	9.53	.375	-	-	-	-	#10-32 x 3/8
MTD-1-0394	10.00	.394	-	-	-	-	M5-0.8 x 10 mm
MTD-1-0433	11.00	.433	4.00	.158	12.80	.504	M5-0.8 x 10 mm
MTD-1-0472	12.00	.472	4.00	.158	13.79	.543	M5-0.8 x 10 mm
MTD-1-0500	12.70	.500	3.18	.125	14.22	.560	#10-32 x 3/8
MTD-1-0551	14.00	.551	5.00	.197	16.31	.642	M5-0.8 x 10mm
MTD-1-0625	15.88	.625	4.76	.188	18.01	.709	#10-32 x 3/8
MTD-1-0709	18.00	.709	6.00	.236	20.80	.819	M5-0.8 x 10 mm
MTD-1-0748	19.00	.748	6.00	.236	21.79	.858	M5-0.8 x 10 mm
MTD-1-0750	19.05	.750	4.76	.188	21.26	.837	#10-32 x 3/8

OTHER SIZES AVAILABLE; SPECIFY BOTH BORE AND KEYWAY

THIS DRAWING IS THE PROPERTY OF MAGNETIC TECHNOLOGIES LTD. AND IS SUPPLIED ON THE EXPRESS CONDITION THAT IT SHALL NOT BE LENT, COPIED, REPRODUCED NO DISCLOSED TO ANY OTHER PERSON, IN WHOLE OR IN PART WITHOUT THE WRITTEN CONSENT OF MAGNETIC TECHNOLOGIES LTD.

USED ON MTD-1	SCALE 1:1	MATERIAL SEE PRT DWG	MAGNETIC TECHNOLOGIES LTD. 43 TOWN FOREST ROAD OXFORD, MA 01540
UNLESS OTHERWISE SPECIFIED: ALL DIMENSIONS ARE IN INCHES TOLERANCES: DECIMAL: .XX ± .01 .XXX ± .005 ANGULAR: ± 1° GEN. CONCENTRICITY: .001 T.I.R. MACH. FILLETS: .010 R MACH. EDGES: .015 R OR CHMF. UNSPECIFIED RADII: .015 R IN MICROINCHES RMS 32 GEOMETRIC: TO MIL-ST'D. 8 REMOVE ALL BURRS & SHARP EDGES		FINISH SEE PRT DWG	
		DRAWN AMD 10/17/14	DESCRIPTION MTD-1 Cut Sheet
		CHECKED	DWG. NO. _____ REV. _____
		SIZE: B	MTD-1-XXX