

Magnetic Couplings



■ **Co-axial Type**



■ **Disc Type**



TRANSMITTING TORQUE THROUGH AIR

Simple Concept:

OPPOSITE POLES ATTRACT

Opposite poles attract. This attraction is how we transmit torque from one magnetic hub to another. By driving the outer magnetic hub, torque is transmitted magnetically to the inner magnetic hub. This can be done through the air or through a non-magnetic containment barrier such as stainless steel or fiberglass, allowing complete isolation of the inner magnetic hub from the outer magnetic hub. There are no contacting parts.

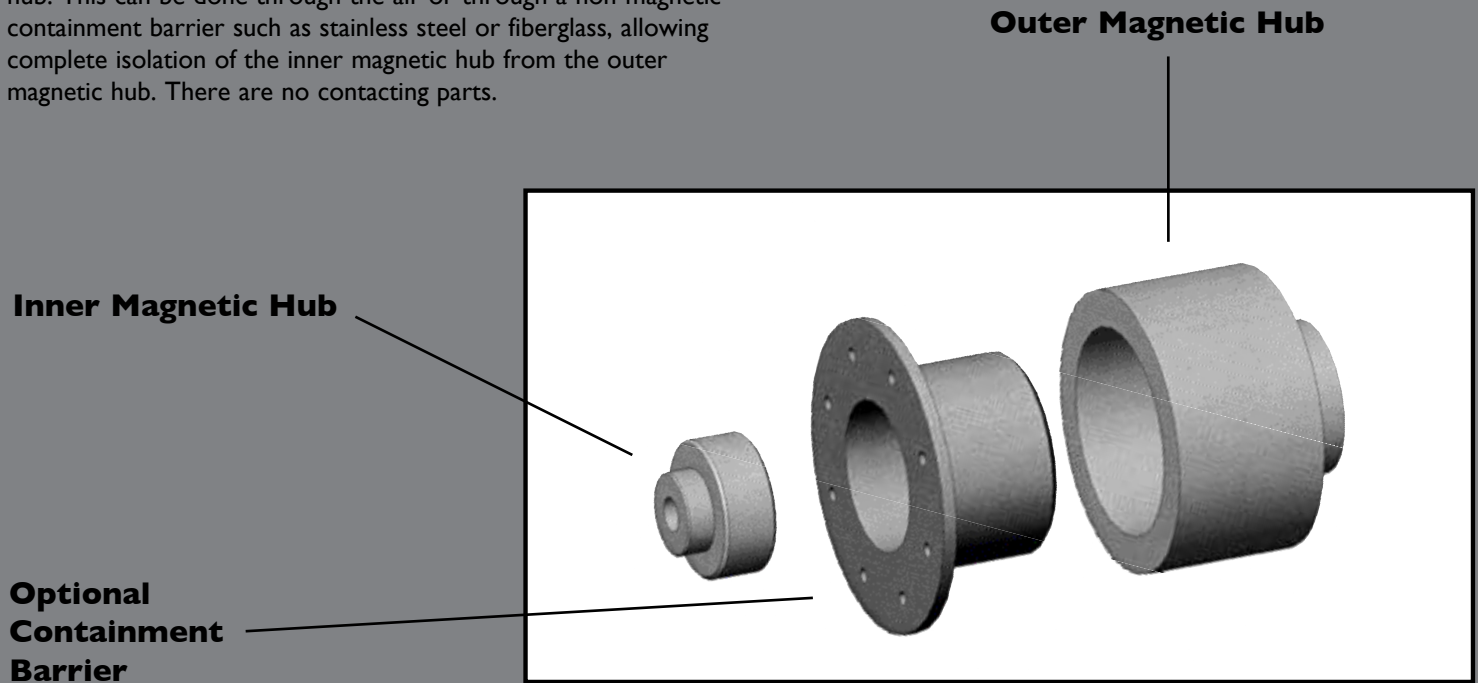

How Co-Axial Couplings Work

The **coaxial coupling** (shown above) consists of two parts. The outer hub consists of a series of rare earth magnets that are ground, potted and attached to the inside diameter of a steel hub. The inner hub consists of a series of rare earth magnets that are ground, potted and attached to the outside diameter of a steel rotor. The inner hub is then completely sealed in stainless steel to protect the magnets and rotor from damage or corrosive substances. Typically there is a radial air gap of up to .275" (7mm) between the inner and outer hubs. Conventional bores and keyways are used to drive the inner and outer hubs.

Technical Data:

	Co-Axial	Disc
Inner Cylinder/Disc	300 stainless steel, hermetically sealed.	400 stainless steel for MTD-0.2 through MTD-4, 300 stainless steel for larger sizes
Outer Cylinder/Disc	mild steel, magnets encapsulated.	
Magnet (Nickel Plated)	NdFeB	NdFeB
Operating Temp. *	140C (284° F)	140C (284° F)

* **Note:** The couplings are also available with SmCo type magnets, rated up to 280C (536° F).

Co-Axial

MAGNETIC COUPLINGS

Note: The dimensions and ratings for all co-axial type couplings are shown using only NdFeB type rare earth magnets. Ratings and dimensions may vary for the SmCo versions.

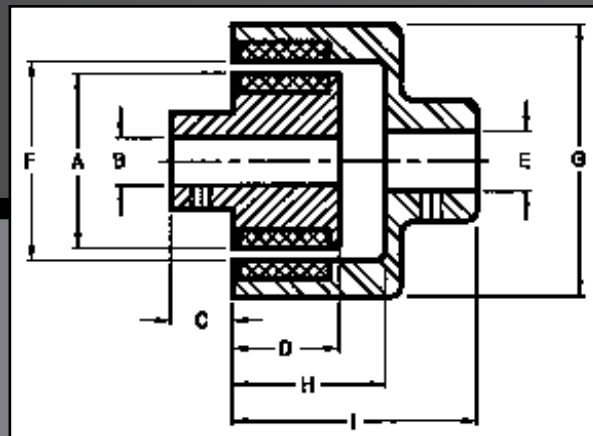

Part Number	Max Speed	Weight (total)	Torque (nominal)	Torque (peak)	INNER HUB				OUTER HUB				
					A	B	C	D	E	F	G	H	I
	rpm	kg lb	Nm in.lbs	Nm in.lbs	mm inch	mm inch	mm inch	mm inch	mm inch	mm inch	mm inch	mm inch	mm inch
MTC-0.1	44000	0.1	0.1	0.2	12.7	5	7	15	6	18	26	19	30
		0.2	1.0	1.75	0.500	0.197	0.28	0.59	0.236	0.710	1.02	0.75	1.18
MTC-0.3	26000	0.3	0.3	0.5	22	8	8	16	8	28	44	22	36
		0.6	2.6	45	0.866	0.315	0.31	0.63	0.315	1.102	1.73	0.87	1.42
MTC-1	22000	0.8	1.0	1.5	28	10	12	20	10	35	52	28	44
		1.7	9	13	1.102	0.394	0.47	0.79	0.394	1.378	2.05	1.10	1.73
MTC-3	18000	1.0	3	3.5	35	12	16	32	12	42	64	42	62
		2.2	27	30	1.378	0.472	0.63	1.26	0.472	1.654	2.52	1.65	2.44
MTC-10	13000	2.5	10	12	58	16	20	35	20	66	90	50	80
		5.5	90	105	2.283	0.630	0.79	1.38	0.787	2.598	3.54	1.97	3.15

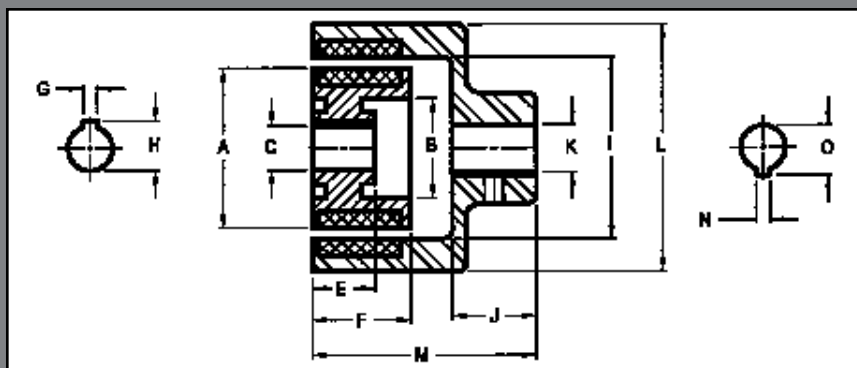

Part Number	Max Speed	Weight (total)	Torque NORMAL	Torque PEAK	INNER HUB								OUTER HUB							
					A	B	C	E	F	G	H	I	J	K	L	M	N	O		
	rpm	kg lb	Nm in.lbs	Nm in.lbs	mm inch	mm inch	mm inch	mm inch	mm inch	mm inch	mm inch	mm inch	mm inch	mm inch	mm inch	mm inch	mm inch			
MTC-16	13000	3	16	26	58	26	14	30	62	5	16.3	66	40	19	92	120	6	21.8		
		6.6	140	230	2.283	1.02	0.551	1.18	2.44	0.197	0.64	2.598	1.58	0.748	3.62	4.72	0.236	0.86		
MTC-22	9400	7	22	35	88	50	20	30	50	6	22.8	97	50	24	124	120	8	27.3		
		16	200	310	3.465	1.97	0.787	1.18	1.97	0.236	0.90	3.819	1.97	0.945	4.88	4.72	0.315	1.07		
MTC-30	9400	8	30	48	88	50	24	30	62	8	27.3	97	50	28	124	130	8	31.3		
		18	265	425	3.465	1.97	0.945	1.18	2.44	0.315	1.07	3.819	1.97	1.102	4.88	5.12	0.315	1.23		
MTC-50	7300	12	50	80	122	80	30	30	50	8	33.3	132	60	38	160	130	10	41.3		
		26	450	708	4.803	3.15	1.181	1.18	1.97	0.315	1.31	5.197	2.36	1.496	6.30	5.12	0.394	1.63		
MTC-65	7300	15	65	100	122	80	30	40	65	8	33.3	132	60	38	160	145	10	41.3		
		33	575	885	4.803	3.15	1.181	1.57	2.56	0.315	1.31	5.197	2.36	1.496	6.30	5.71	0.394	1.63		
MTC-80	6500	19	80	130	142	90	35	40	65	10	38.3	152	80	42	180	165	12	45.3		
		42	710	1151	5.591	3.54	1.378	1.57	2.56	0.394	1.51	5.984	3.15	1.654	7.09	6.50	0.472	1.78		
MTC-110	6500	22	110	165	142	90	35	40	80	10	38.3	152	80	42	180	180	12	45.3		
		48	1000	1460	5.591	3.54	1.378	1.57	3.15	0.394	1.51	5.984	3.15	1.654	7.09	7.09	0.472	1.78		
MTC-140	6500	29	140	210	142	90	40	40	110	12	43.3	152	80	48	180	210	14	51.8		
		64	1250	1859	5.591	3.54	1.575	1.57	4.33	0.472	1.70	5.984	3.15	1.890	7.09	8.27	0.551	2.04		

Co-Axial MAGNETIC COUPLINGS

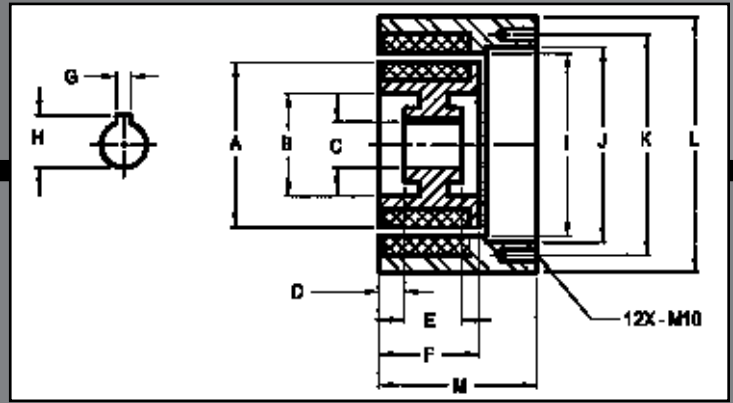

Part Number	Max Speed rpm	Weight (total) kg lb	Torque NORMAL Nm in.lbs	Torque PEAK Nm in.lbs	INNER HUB								OUTER HUB				
					A	B	C	E	F	G	H	I	J	K	L	M	
MTC-180	6200	23	180	290	142	90	40	60	50	140	12	43.3	152	156	170	190	
		51	1600	2567	5.59	3.54	1.575	2.36	1.97	5.51	0.472	1.70	5.98	6.142	6.69	7.48	
MTC-220	6200	26	220	330	142	90	48	70	60	160	14	51.8	152	156	170	190	
		57	2000	2921	5.59	3.54	1.890	2.76	2.36	6.30	0.551	2.04	5.98	6.142	6.69	7.48	
MTC-280	6200	30	280	380	142	90	48	90	60	180	14	51.8	152	156	170	190	
		66	2500	3363	5.59	3.54	1.890	3.54	2.36	7.09	0.551	2.04	5.98	6.142	6.69	7.48	

Optional Containment Barrier

An optional stainless steel barrier can be used to separate the atmosphere or fluid surrounding the inner and outer hubs. This eliminates the need for a rotating shaft seal. Both standard and custom barrier designs up to 75 hp are available. All sizes over MTC-10-SB are made to order. All designed applications are economically produced, even in small quantities.

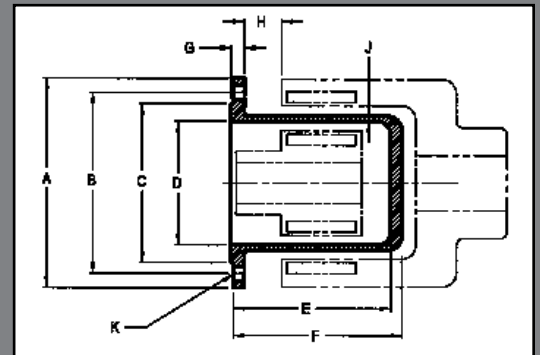

Part Number	A	B	C	E	F	G	H	I	J	K, # of Holes
MTC-0.1-SB	mm	mm	mm	mm	mm	mm	mm	mm	mm	mm x qty
	inch	inch	inch	inch	inch	inch	inch	inch	inch	inch
MTC-0.3-SB	43	34.1	-	15	28	30	5	6.6	0.5	5.5 x 4
	1.69	1.343	-	0.579	1.10	1.16	0.20	0.26	0.019	0.22
MTC-1-SB	49	40	30	24	30	32	5	7	1	5.5 x 4
	1.93	1.575	1.18	0.945	1.18	1.26	0.20	0.28	0.039	0.22
MTC-3-SB	55	46	38	30	35	37	5	7	1	5.5 x 6
	2.17	1.811	1.50	1.181	1.38	1.46	0.20	0.28	0.039	0.22
MTC-10-SB	66	55	44	38	45	50	7	5	1	6.6 x 6
	2.60	2.165	1.73	1.496	1.77	1.97	0.26	0.21	0.039	0.26
MTC-10-SB	96	83	73	60	62	67	15	6	1	6.6 x 6
	3.78	3.268	2.87	2.362	2.44	2.64	0.59	0.24	0.039	0.26

Note: The MTC-0.1 through -10 containment shells are 316 stainless, and are rated to a minimum of 450 psi. Containment shells for other sizes are made and rated according to customer requirements.

TRANSMITTING TORQUE THROUGH AIR

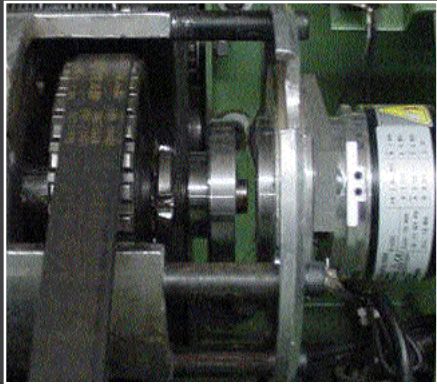

Vibration isolation on
high speed encoder using
Disc Type Coupling



Indexing application using
Disc Type Coupling



Chemical pump application using
Co-Axial Type Coupling



Belt-driven mixer using
Co-Axial Type Coupling



***Do you have our latest
Brake and Clutch catalog?***